

# COEO

a social seat



natalie  
garkey

# Home comes first.

“We believe in creating and sourcing pieces that move with you and are meant to be enjoyed over a lifetime – from home to home, generation to generation. For us, that means exceptionally crafted, built-to-last, and beautifully designed furnishings.”

Like most successful stories, DWR began by trying to find the solution to a problem.

The founder, Rob Forbes, had trouble finding modern designer furniture in the United States.

He started DWR to make these pieces “within reach.”

The company started out by selling products that were in stock and ready to ship, which was a change from the traditional furniture buying process at the time.

DWR is now a part of the Miller Knoll collective and continues to sell the designs of famous designers such as Charlotte Perriand and Alvar Aalto.

# CHARLOTTE PERRIAND



'Mexique' bookcase



Lc4 Chaise Longue

Perriand introduced the '**Machine Age**' aesthetic to interiors through her use of **steel**, aluminium, and glass in furniture.

# ALVAR AALTO



Cantilever Chair



Stool 60 Kivet



Aalto was an influential designer in midcentury design; his invention of **bent plywood** furniture and the "L-leg" stool had a huge impact on other designers like Charles and Ray Eames.



DESIGN  
WITHIN  
REACH





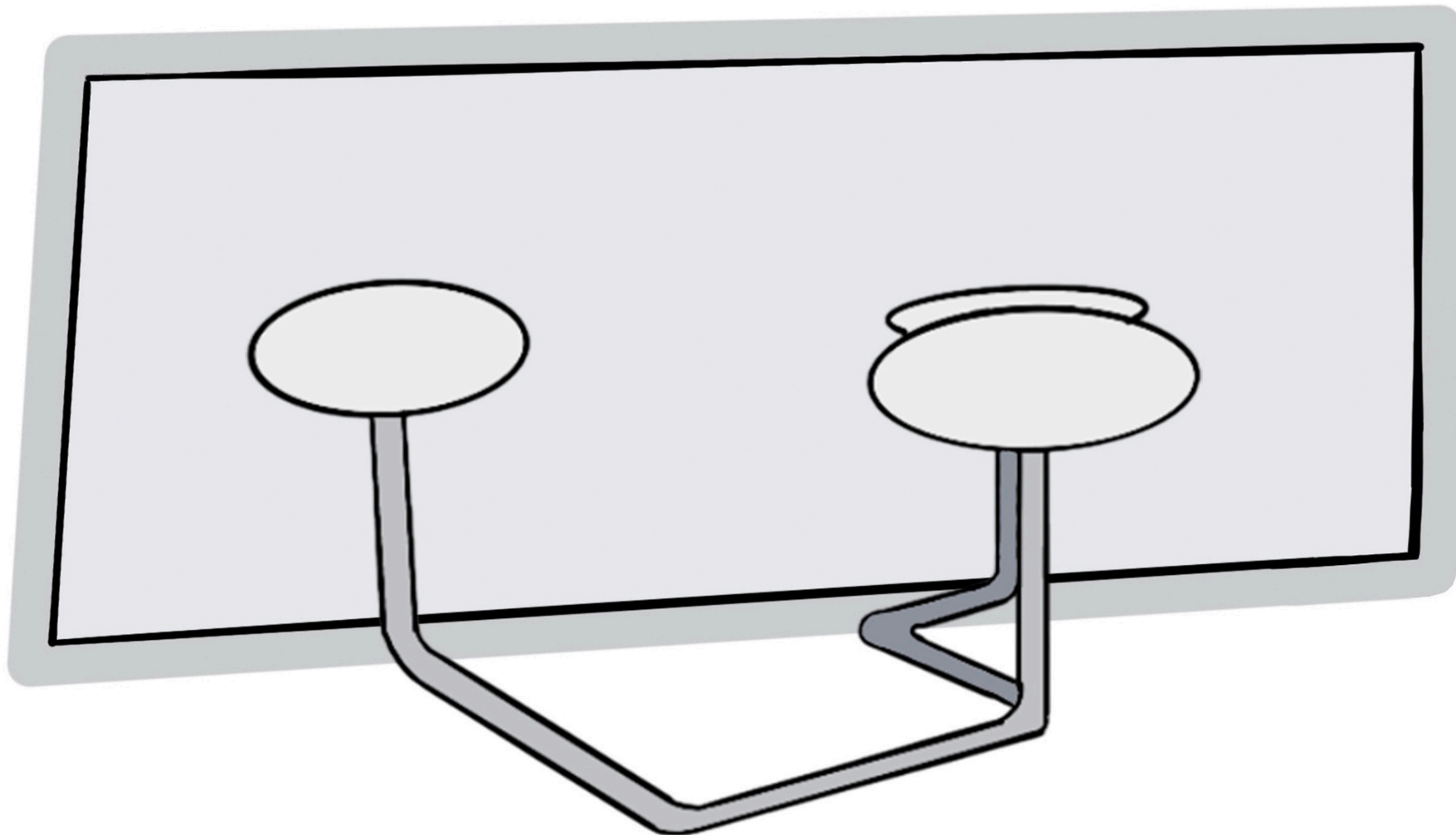

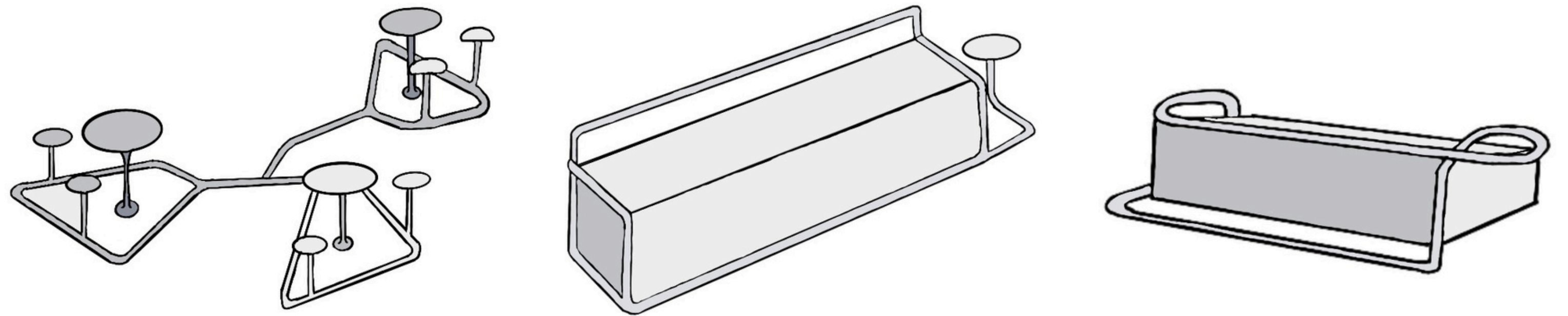
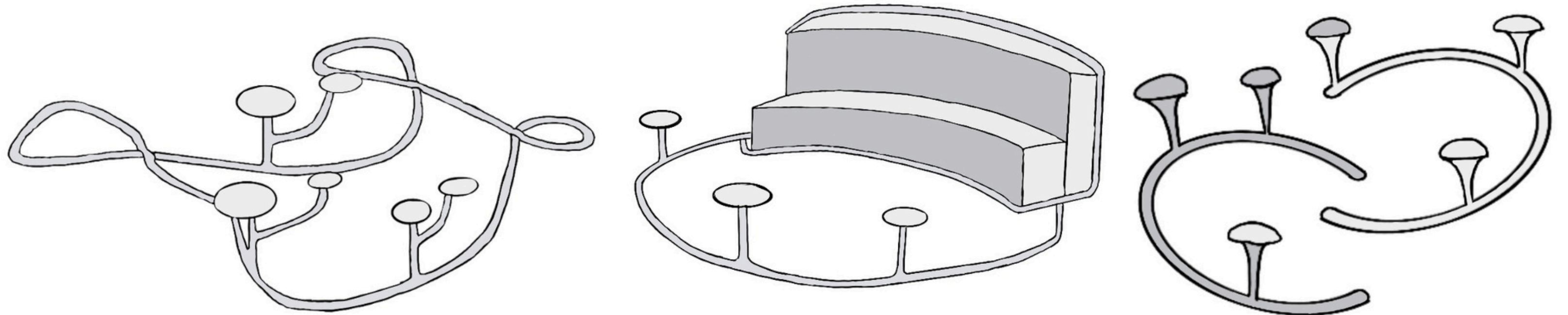
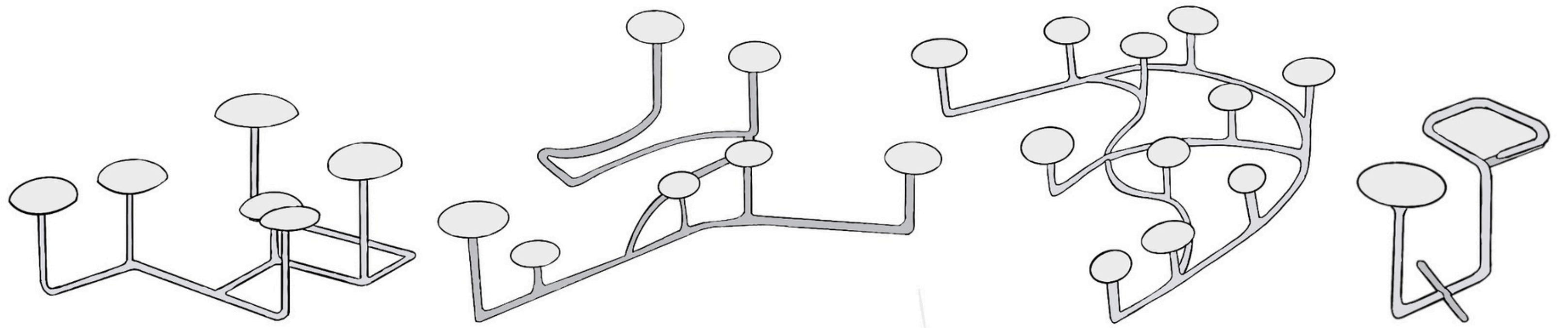



Saarinen Tulip Side Chair



Saarinen Dining Table

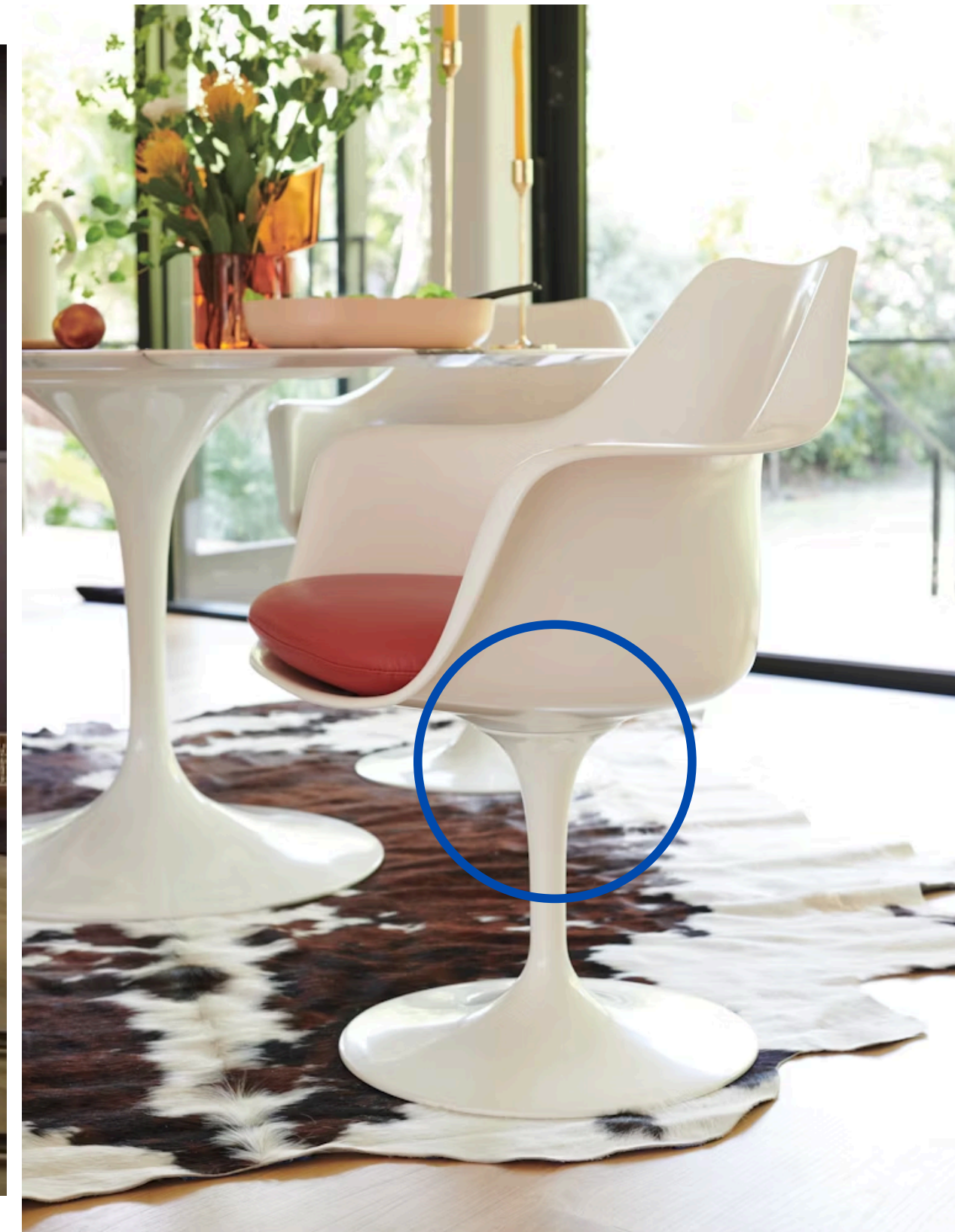

Saarinen Tulip Armchair

# Eames Hang-It-All by Herman Miller

"elevated the everyday coat rack into something inventive and fun"

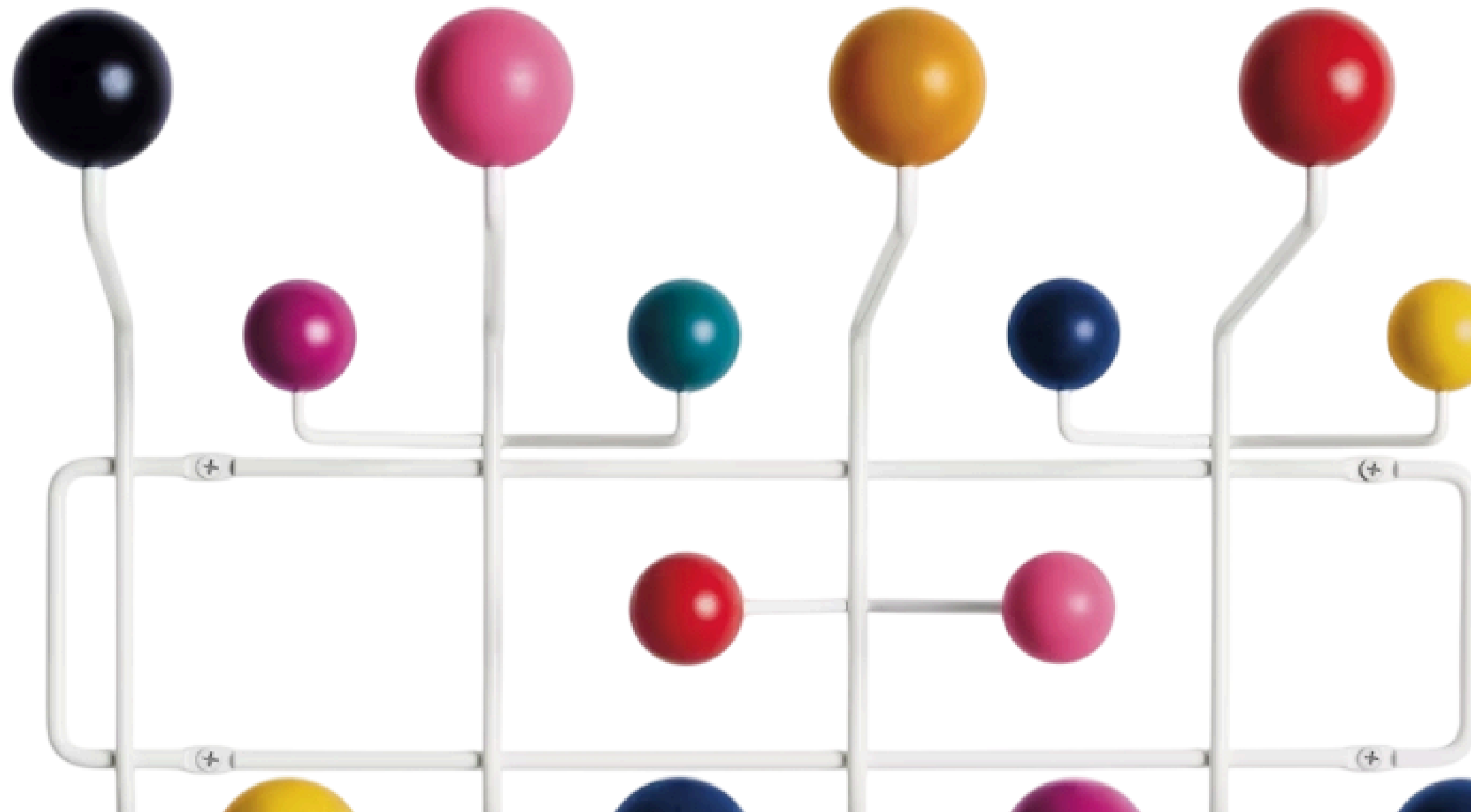
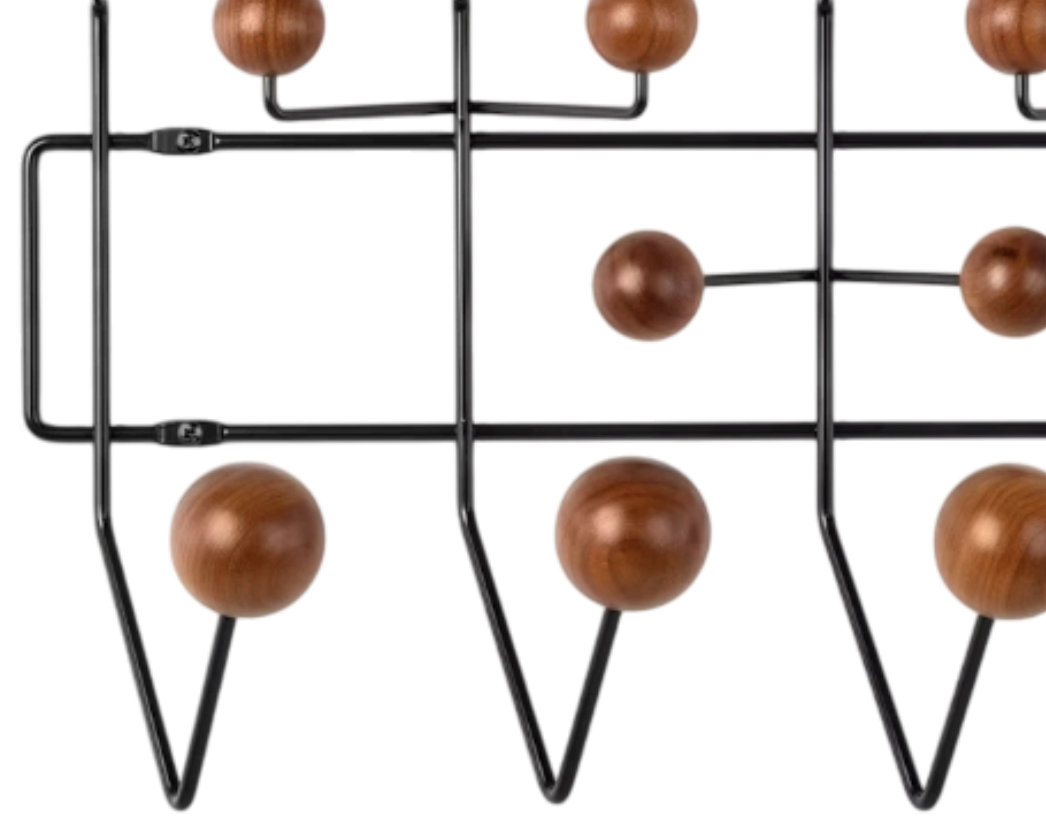
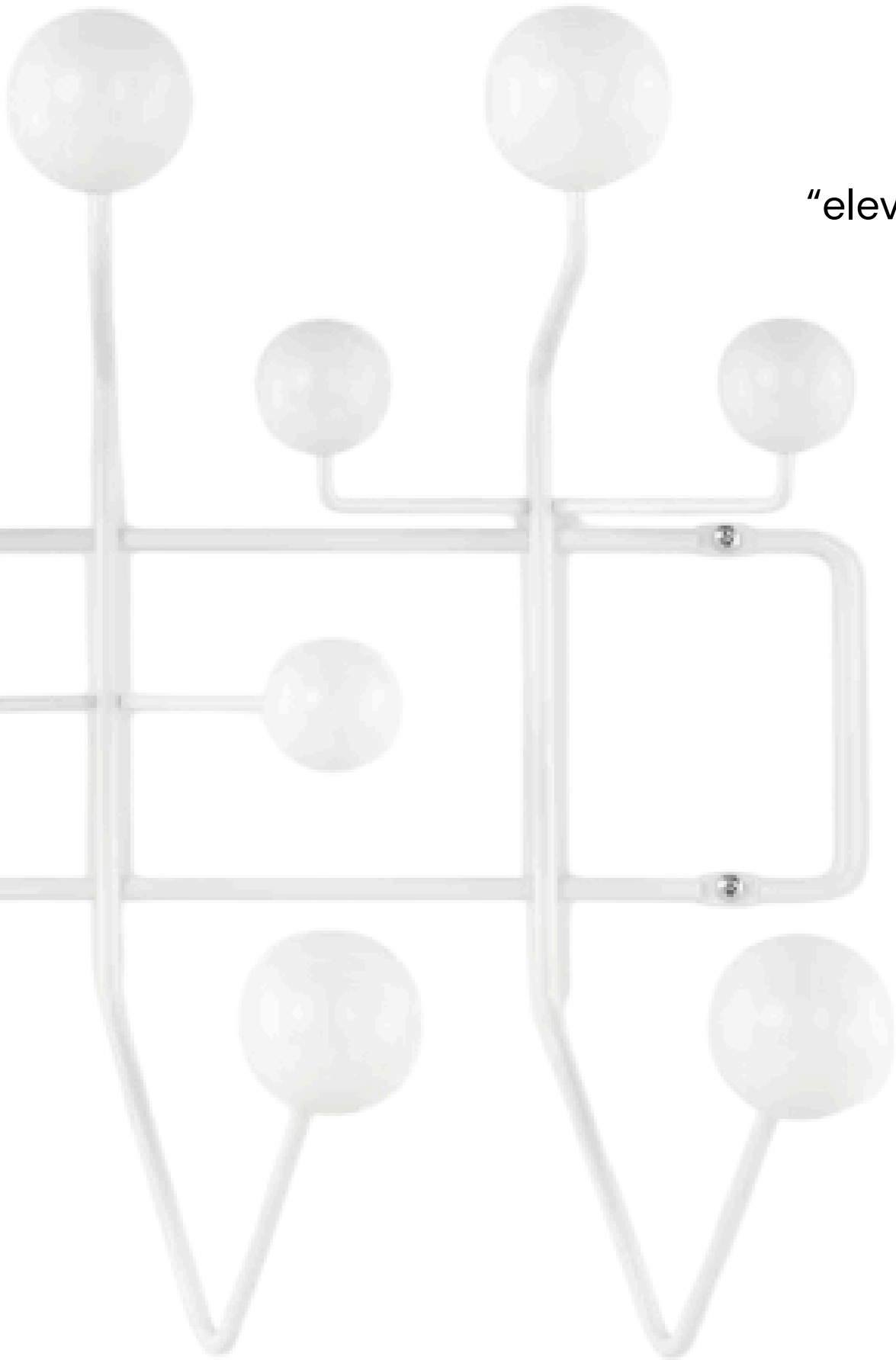

# Knoll Textiles

The company focuses on clean, inviting, and warm design. To accomplish this mission, Knoll Textiles was established, where they produce textiles that match the clean, functional aesthetic of modern architecture.

The Knoll Hourglass fabric is timeless and durable, making it ideal for both commercial and high-end residential upholstery.

Abrasion performance: 100,000 double rubs

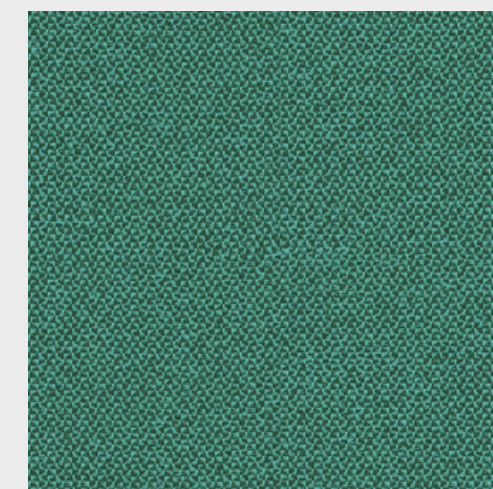
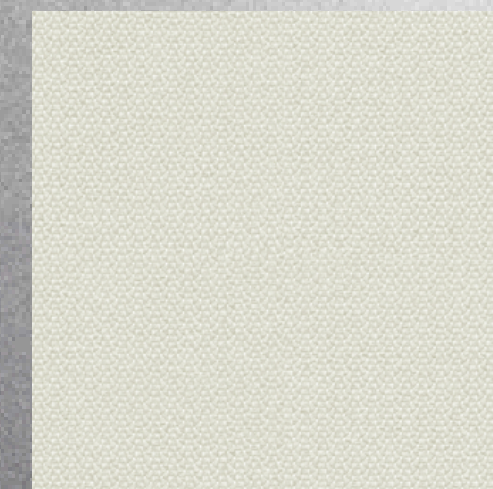
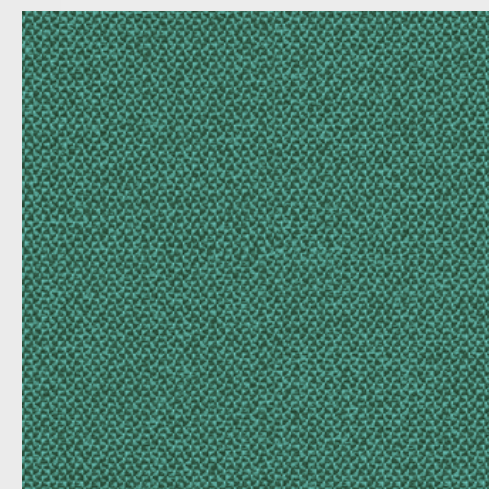
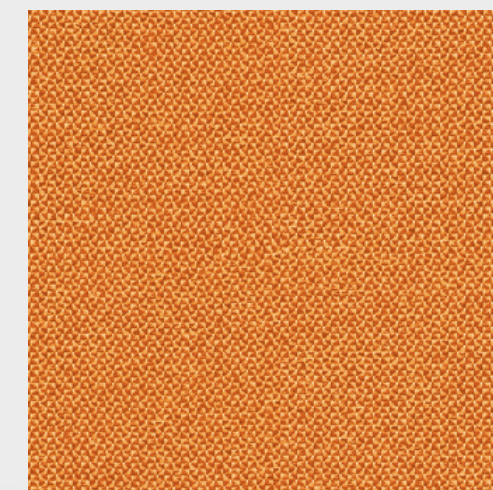
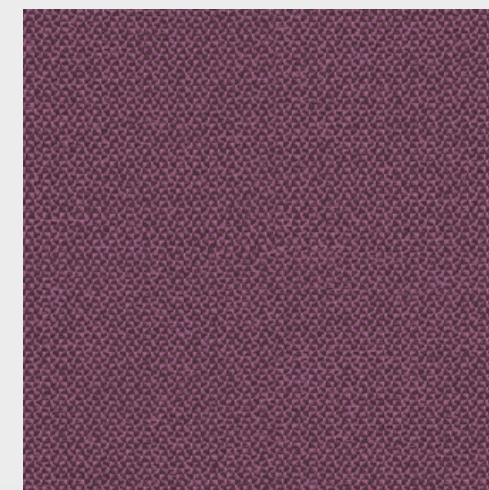
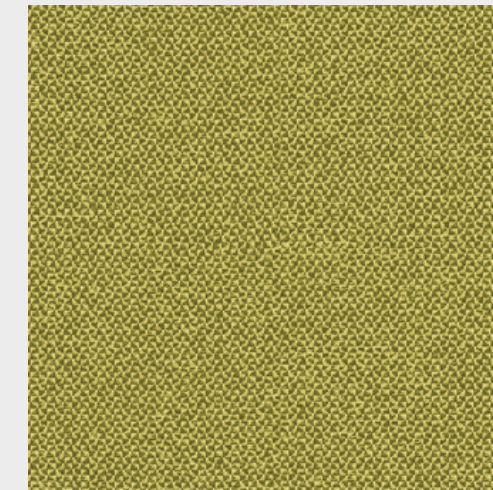
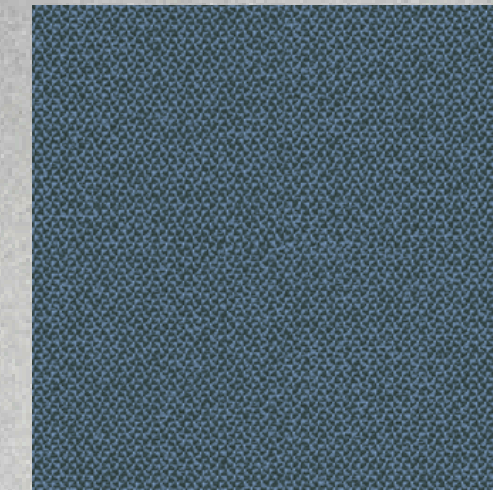
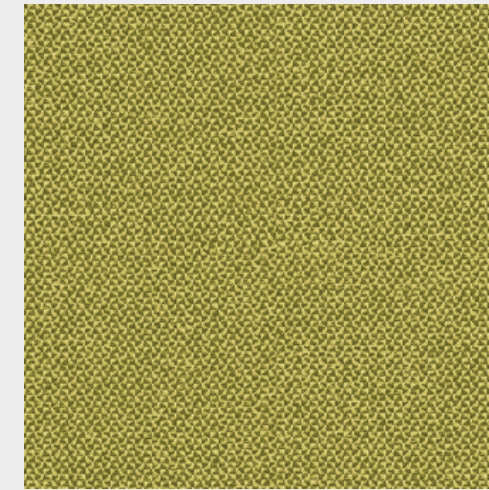
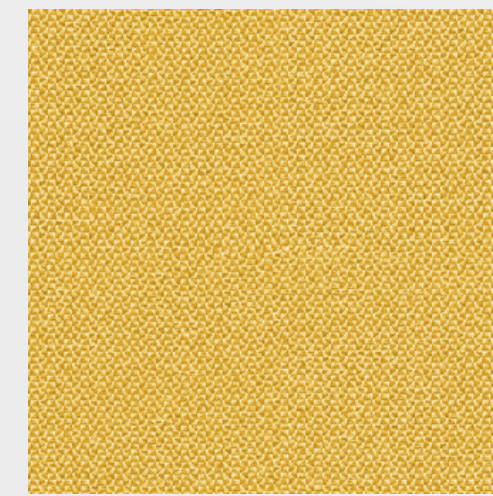
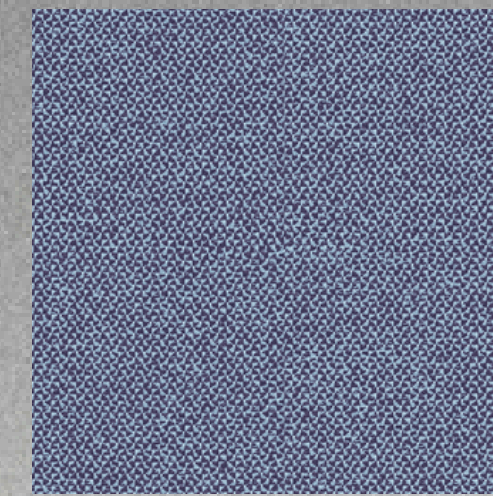
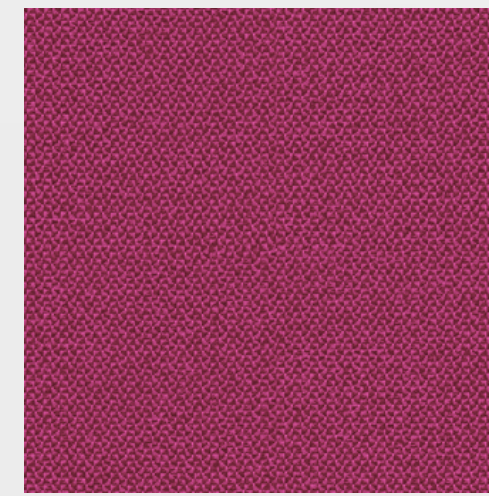

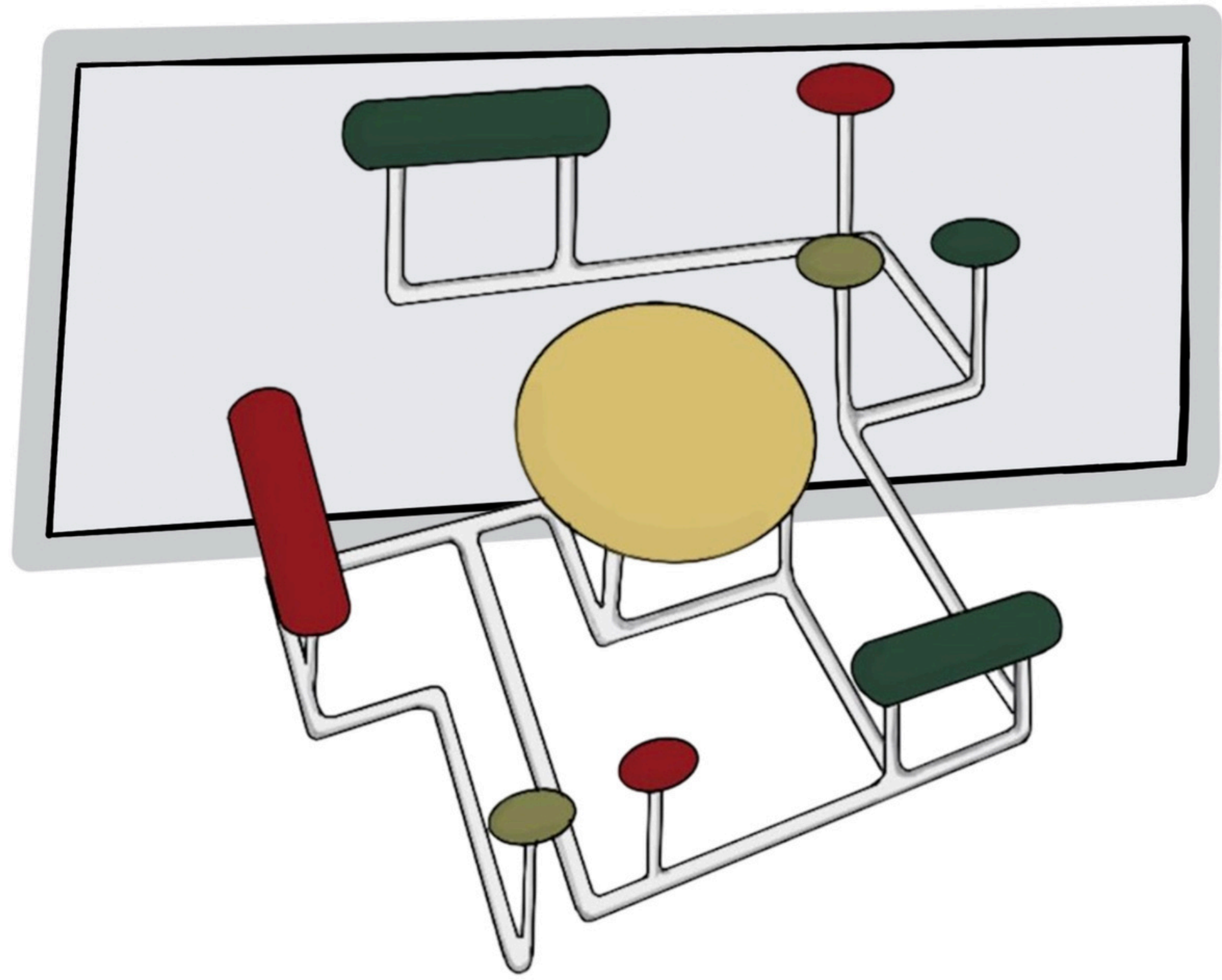
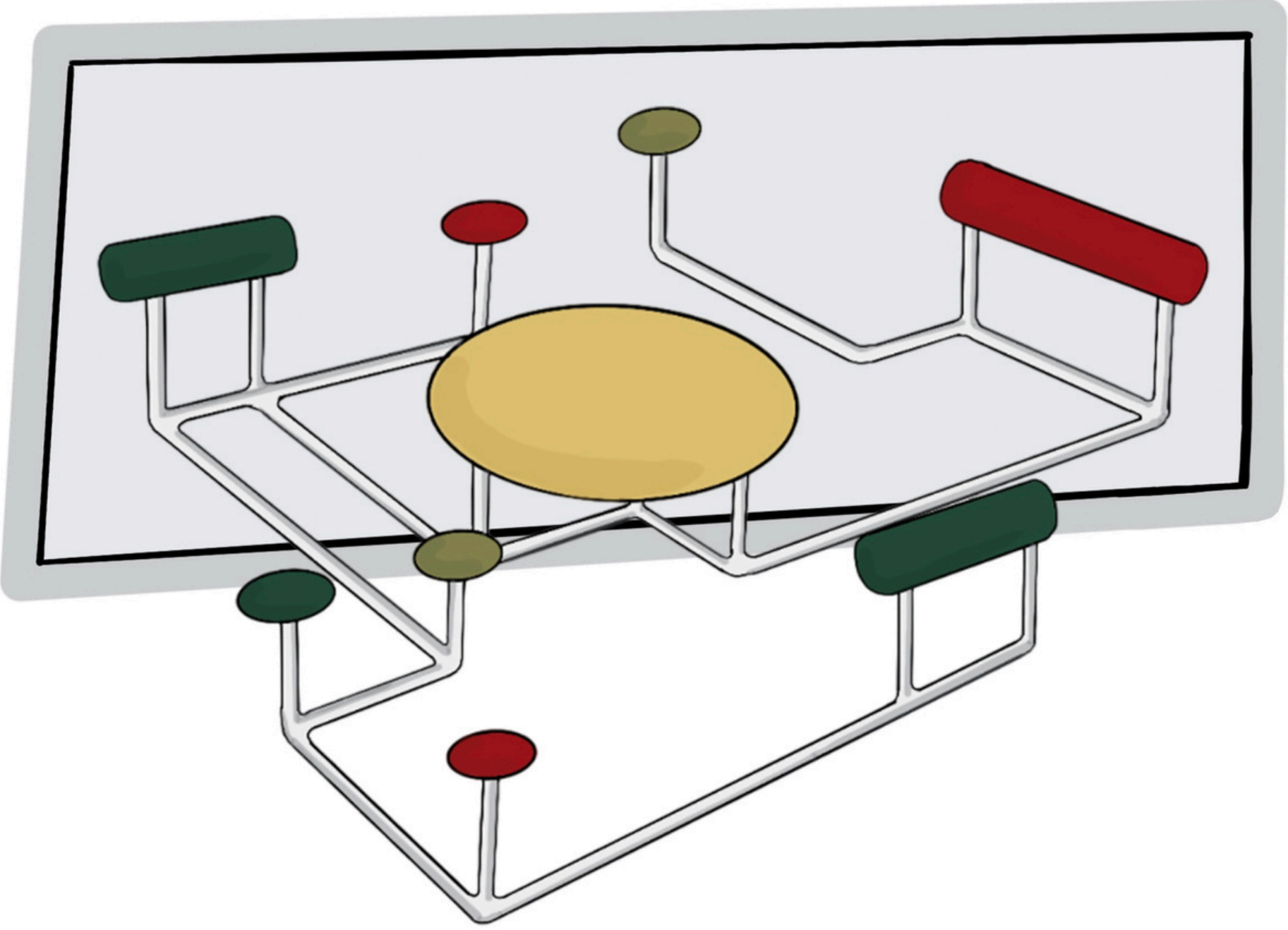

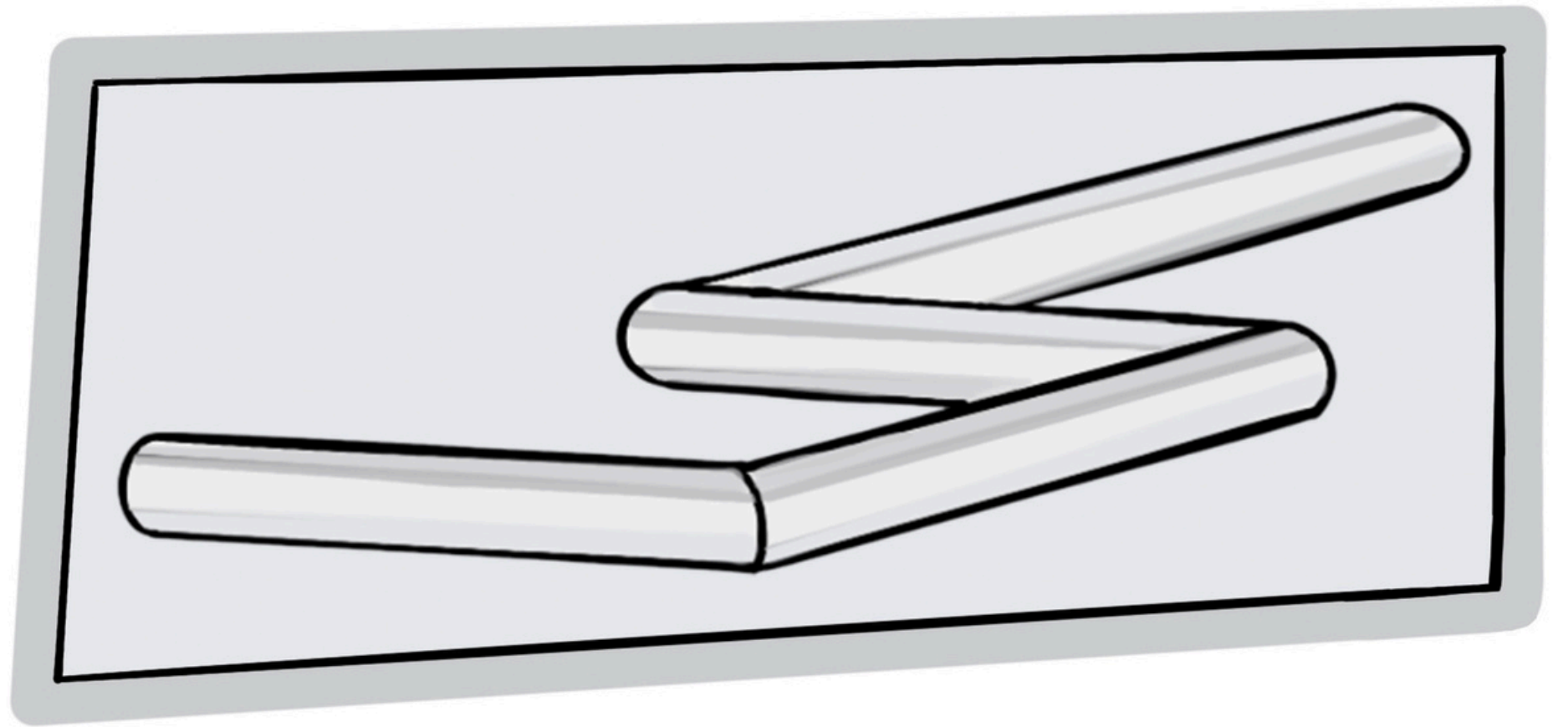
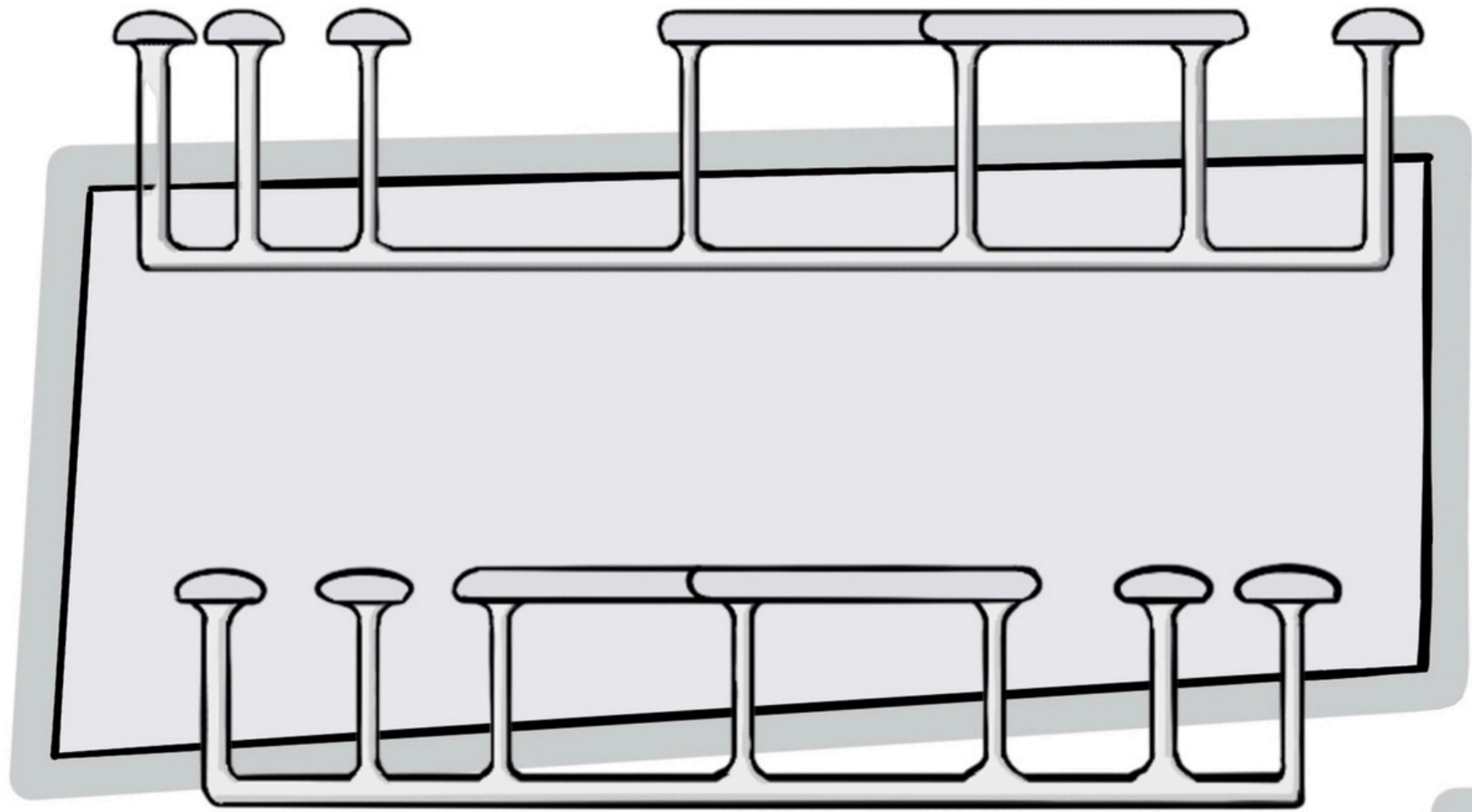

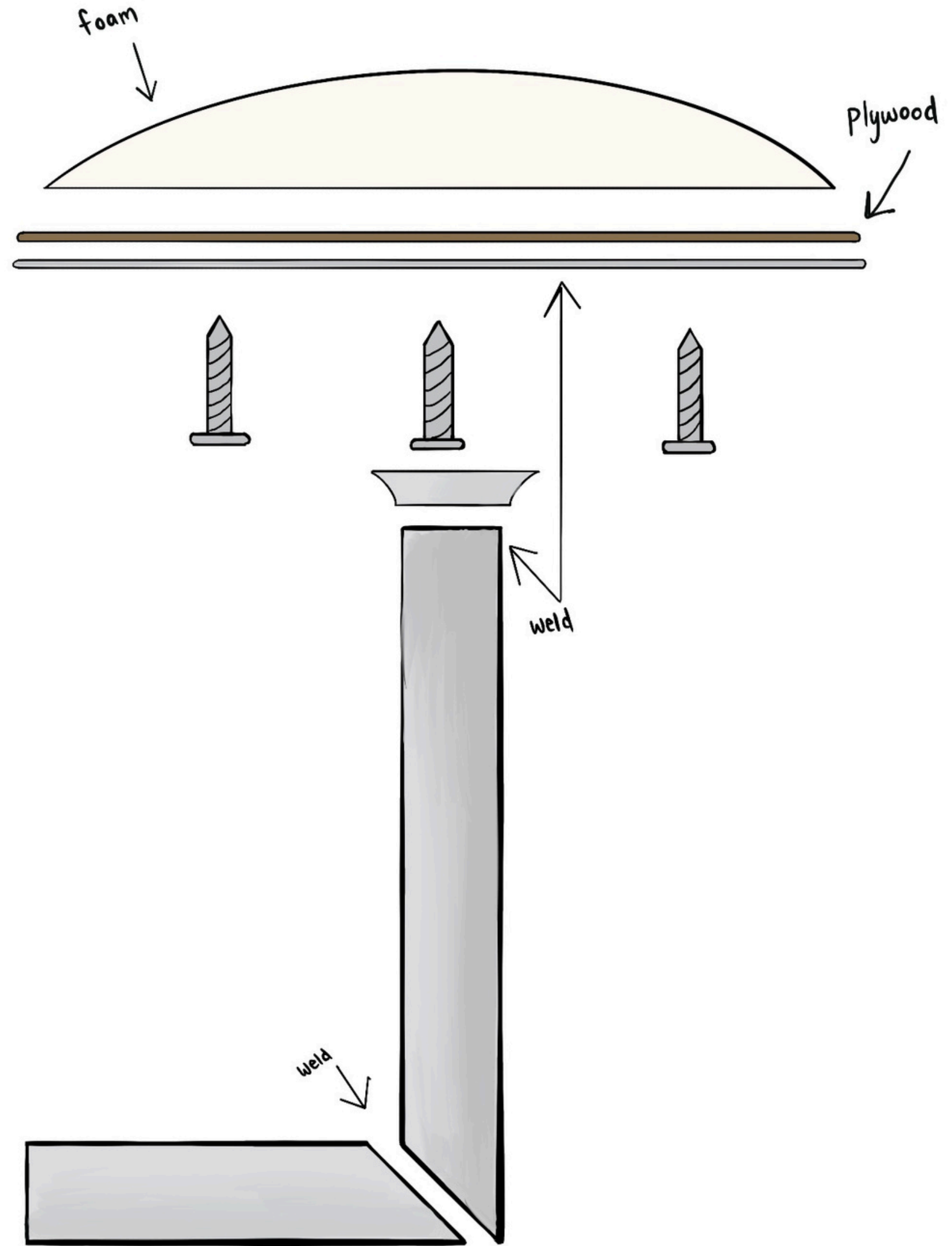







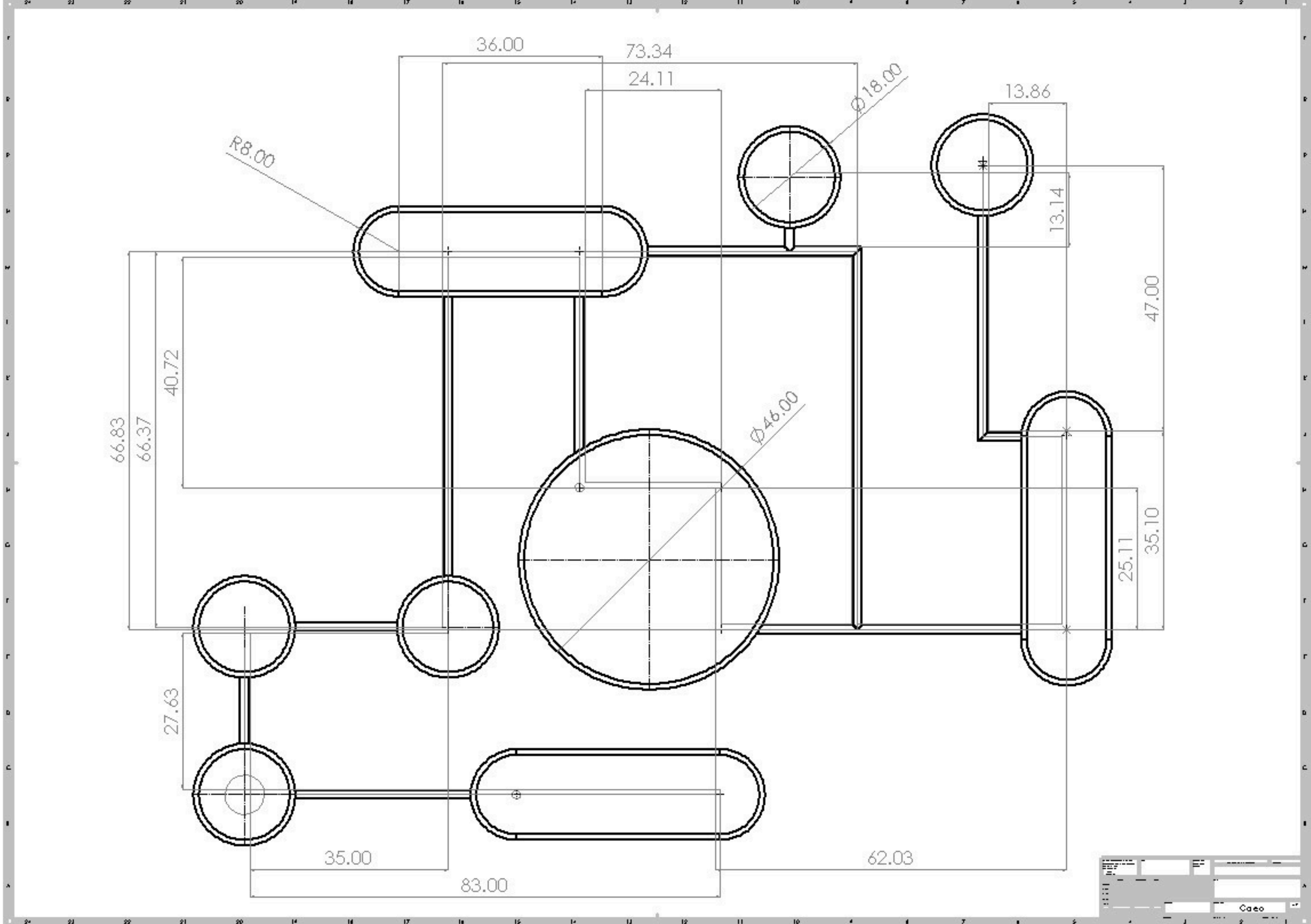

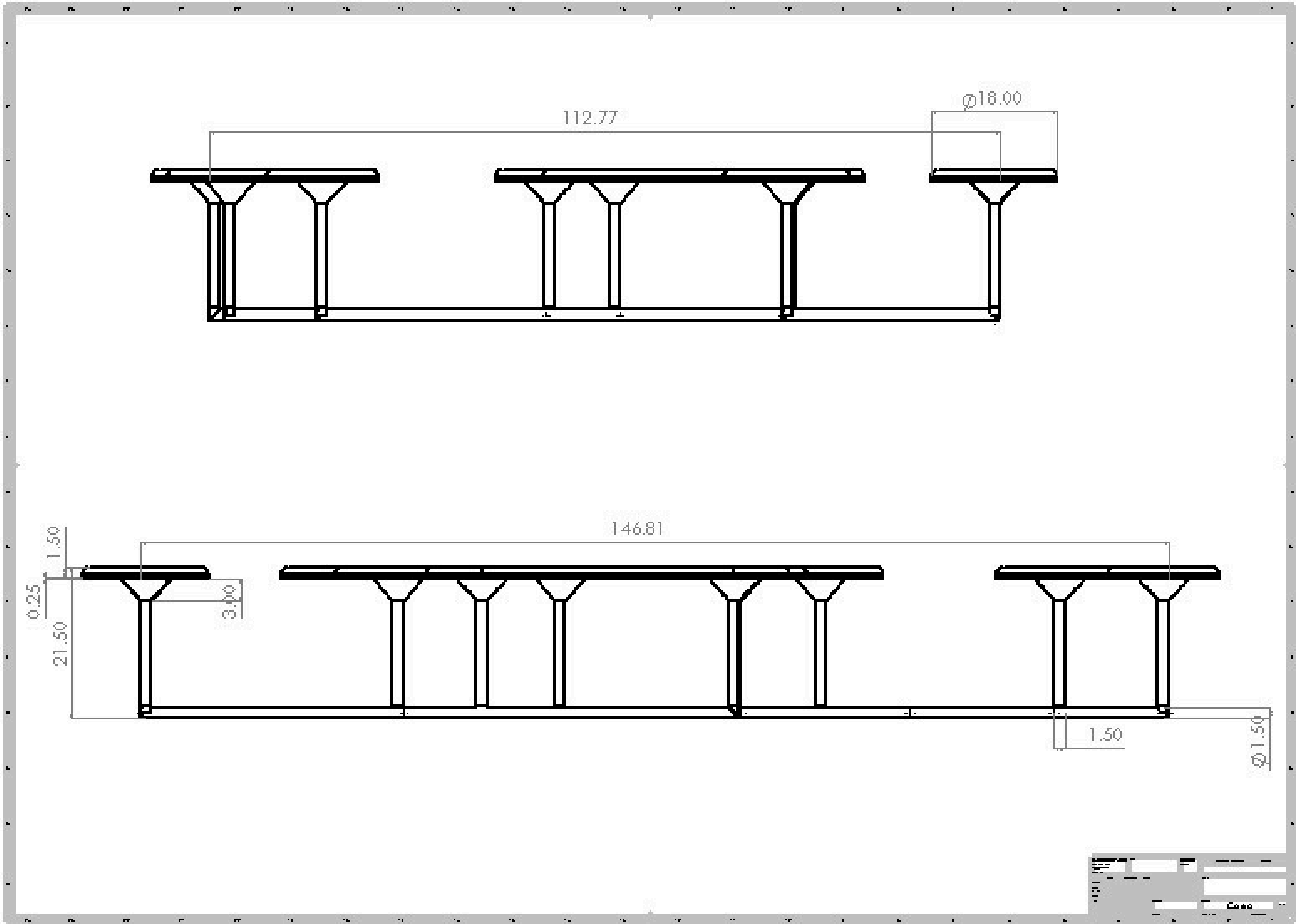

NO	DESCRIPTION	QUANTITY	UNIT
1	REINFORCEMENT		
2	CONCRETE		
3	FORMWORK		
4	LABOR		
5	OTHER		
TOTAL			



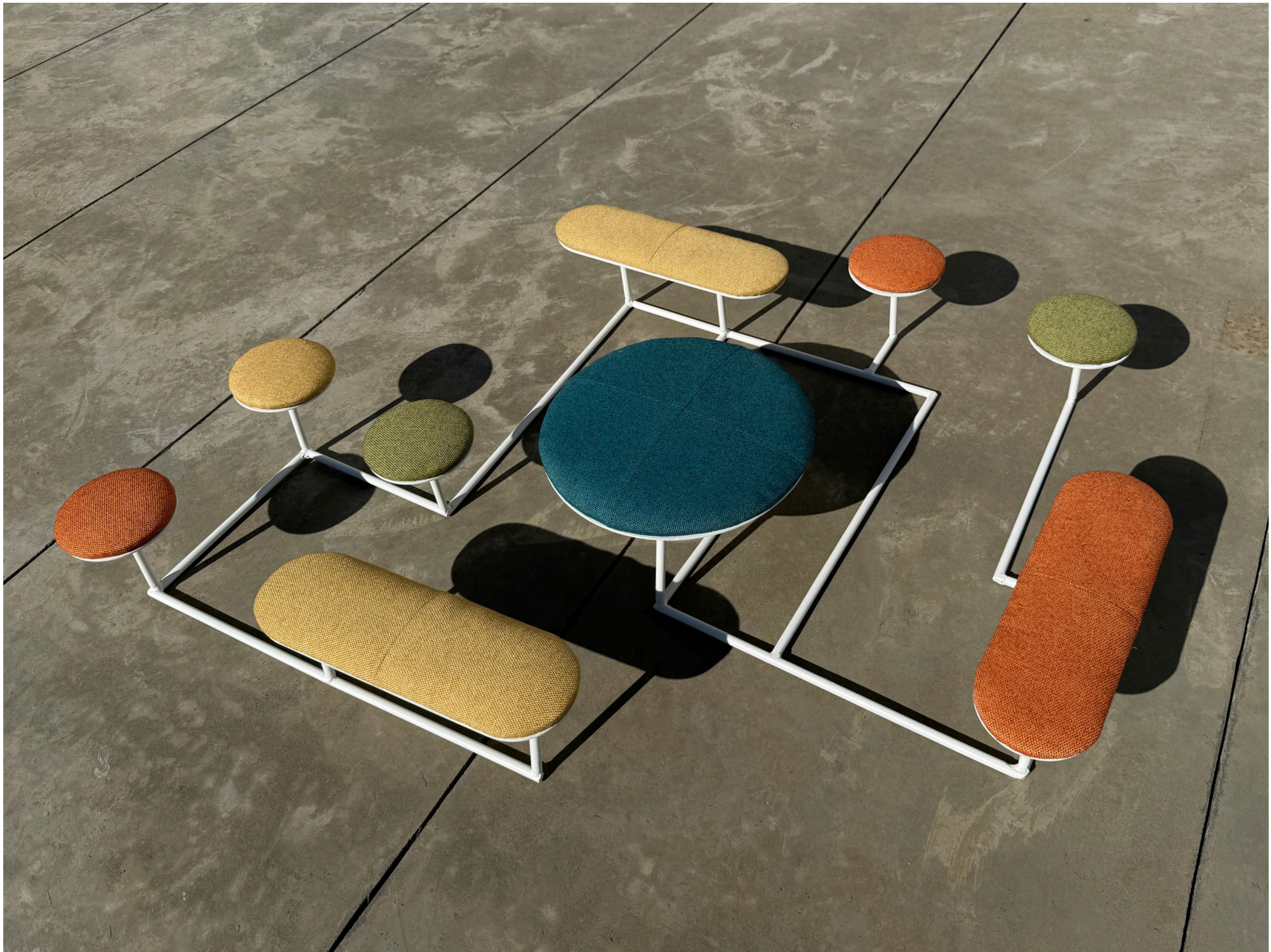







THANK YOU

