



# EMBRA

A smart-thermal wearable for hemiplegic limbs.

## Inspiration

Based on in-depth research with caregivers and medical experts, this project addresses core challenges in hemiplegia care: patients' impaired limb temperature regulation—often causing cold extremities, poor circulation, and stiffness—and caregivers' difficulty in continuous manual monitoring. The solution utilizes graphene-based heating technology, offering superior flexibility for comfort and uniform heat distribution to minimize overheating risks for patients with sensory deficits.



## Design Description

EMBRA is specially designed for people with hemiplegia. EMBRA's intelligent temperature-control system monitors limb temperature in real time and displays the data on both the product control panel and a companion app, alerting caregivers and family members. It also utilizes graphene-based heating, which ensures even warmth distribution, softness, lightweight wearability, and high safety.

## Details

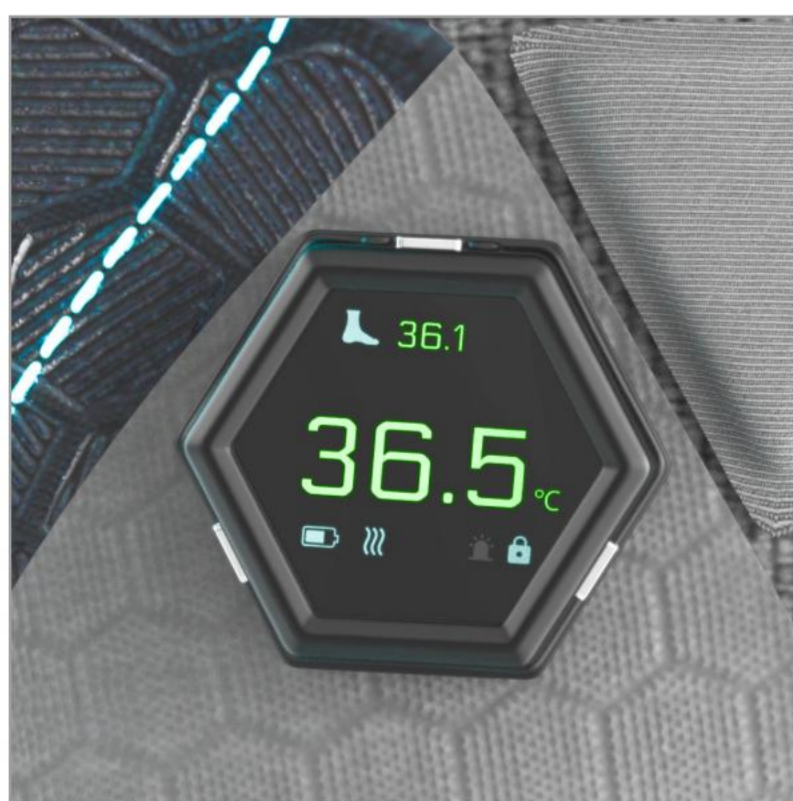

Smart Main Control Board

Precision Temperature Control



Temperature Sensor Array

Dual-Side Comparison



Light-Emitting Woven Conductor

Intuitive Display



Heating Drive Battery

Portable and detachable

# Research Abstract

For hemiplegic patients, impaired central sympathetic control often results in lower temperature in the affected limb compared to the healthy side. In cold conditions, this increases the risk of muscle spasms and ischemic ulcers. Caregivers must therefore frequently check the limb manually while ensuring warmth without causing low-temperature burns—a challenge due to the patient’s reduced sensation.



# Blueprint

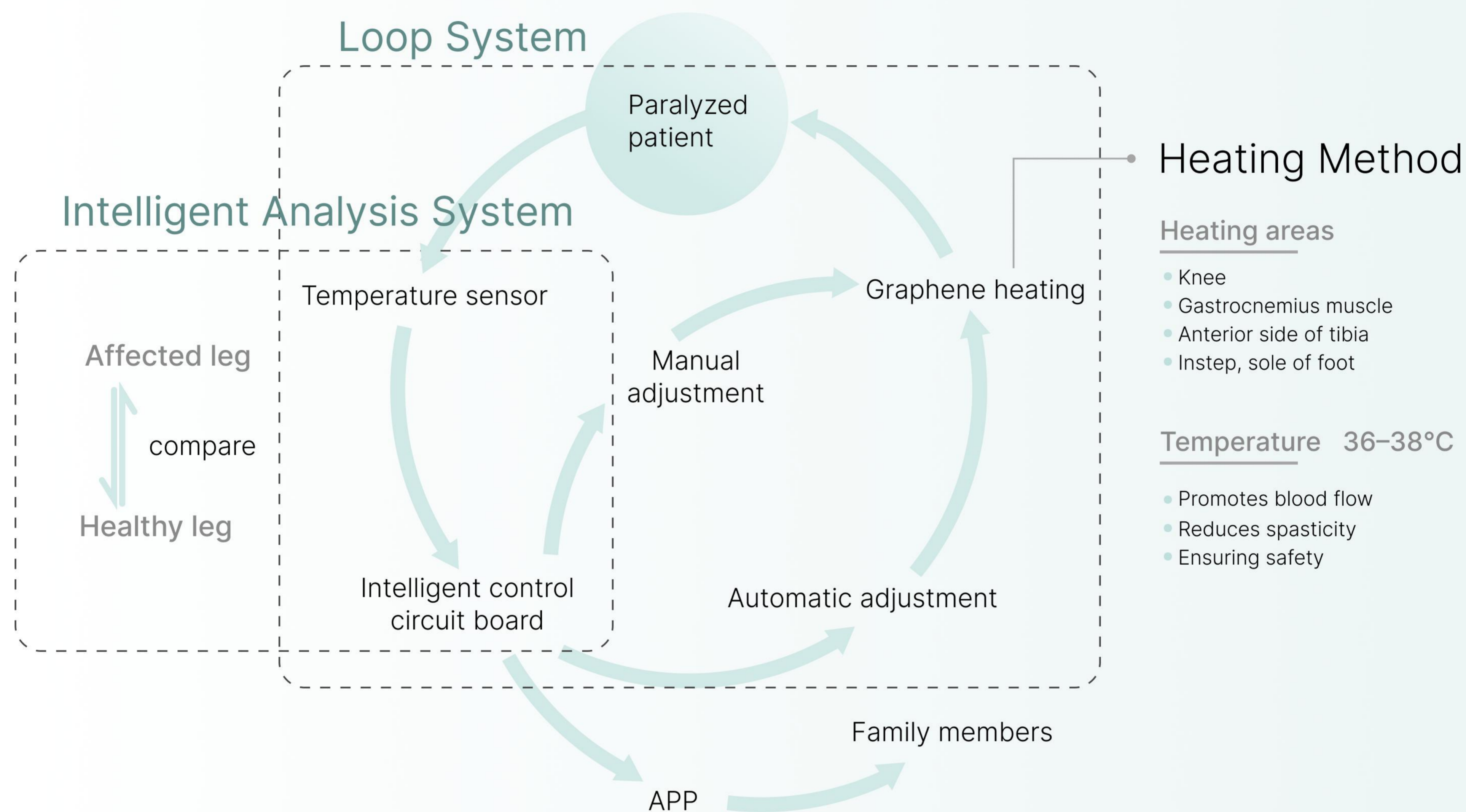

# Storyboard

**1** Exhibit uneven leg temperatures



**2** Repeatedly check on the patient



**3** Lack sensation

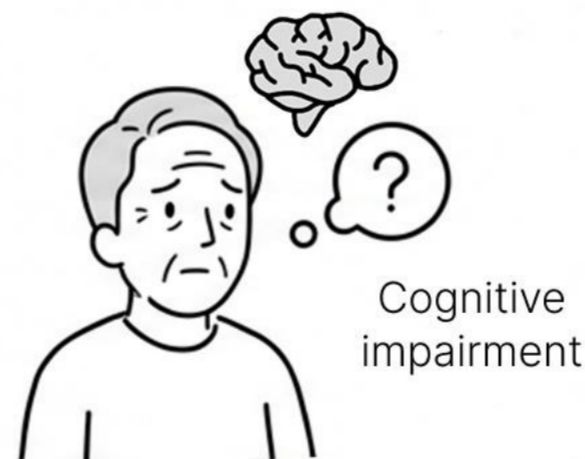

**4** Purchase the product



**5** Wear the socks effortlessly



**6** Power on by long-pressing

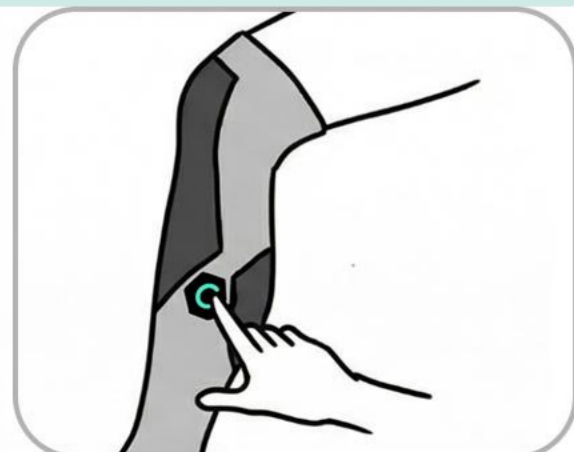

**7** Maintain inter-leg data communication

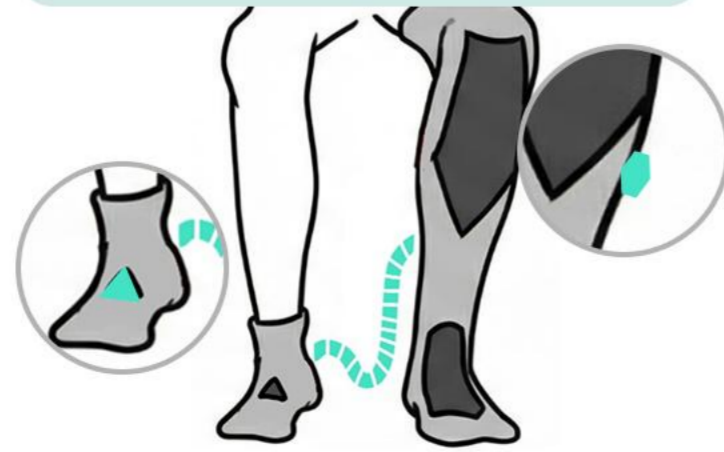

**8** Enjoy intelligent heating and warmth retention



**9** Receive alerts for temperature anomalies



**10** Monitor the patient remotely via app



# Exploded View

# Graphene Composite Heating Sheet

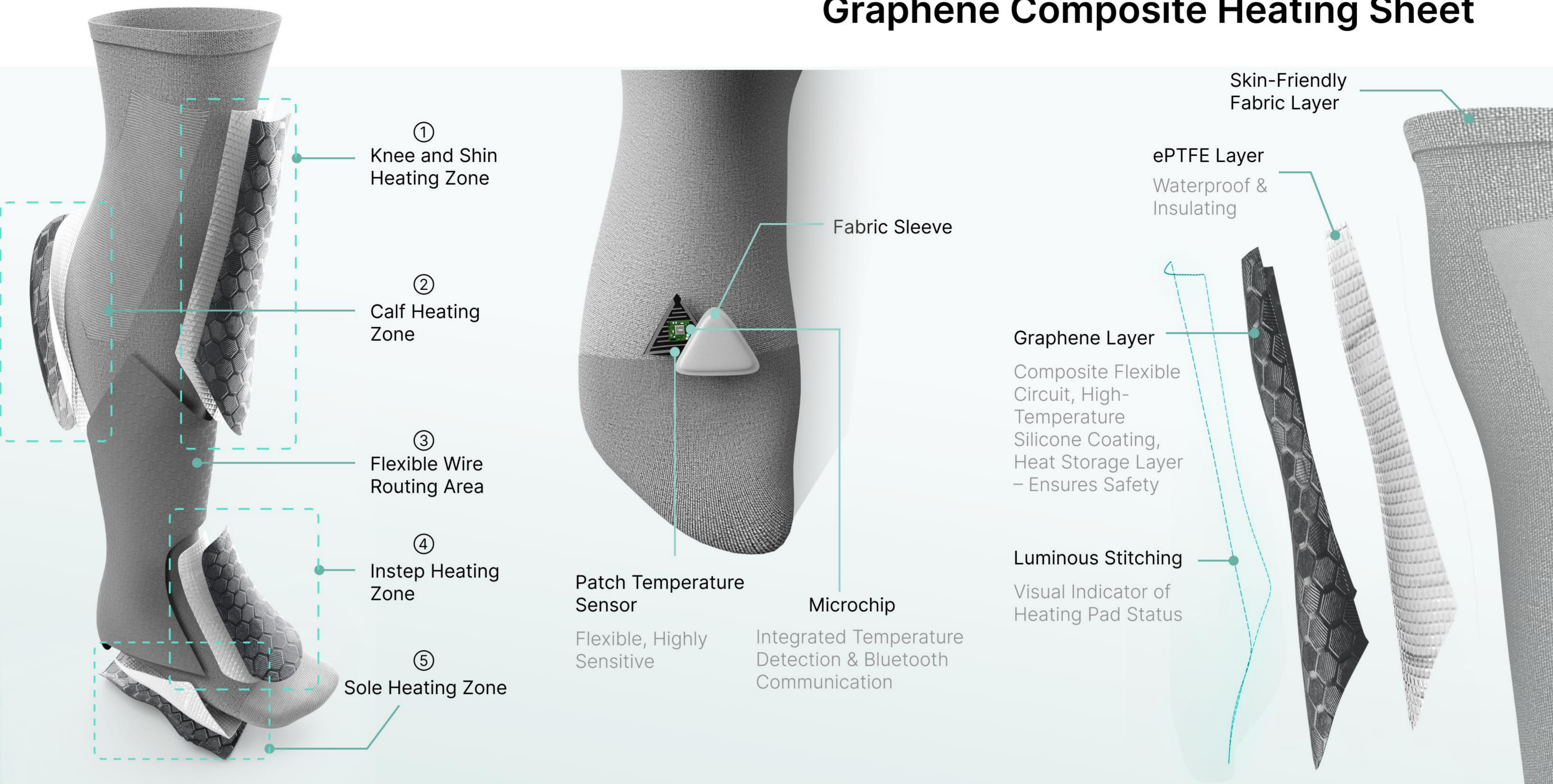

# Main Controller

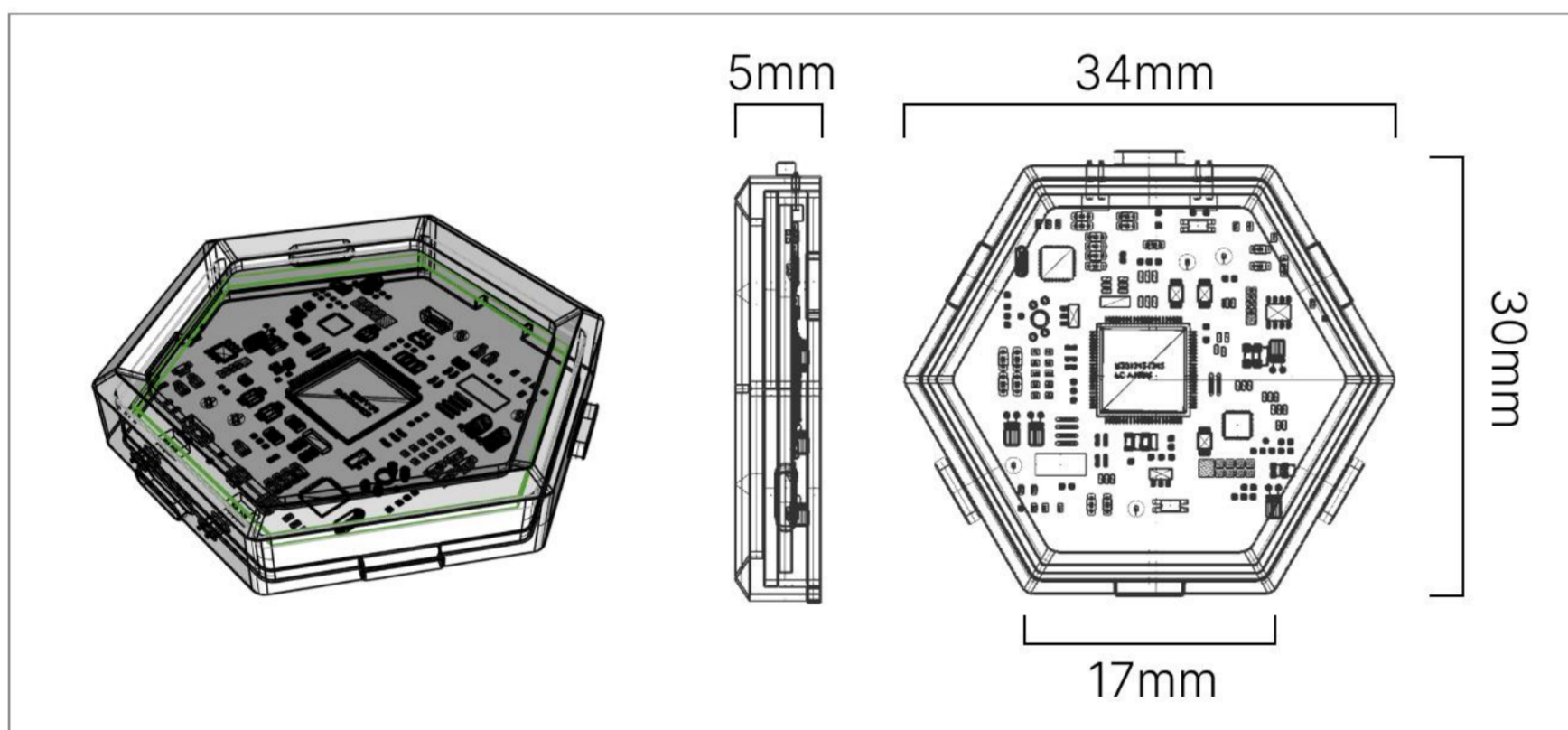

- Main Control MCU
- Bluetooth/Wi-Fi Communication Module
- Safety Protection Circuit
- Data Storage Module
- Multi-Channel Temperature Sensor Interface
- Heating Drive Module
- Power Management Module
- AI Cloud Deep Analysis

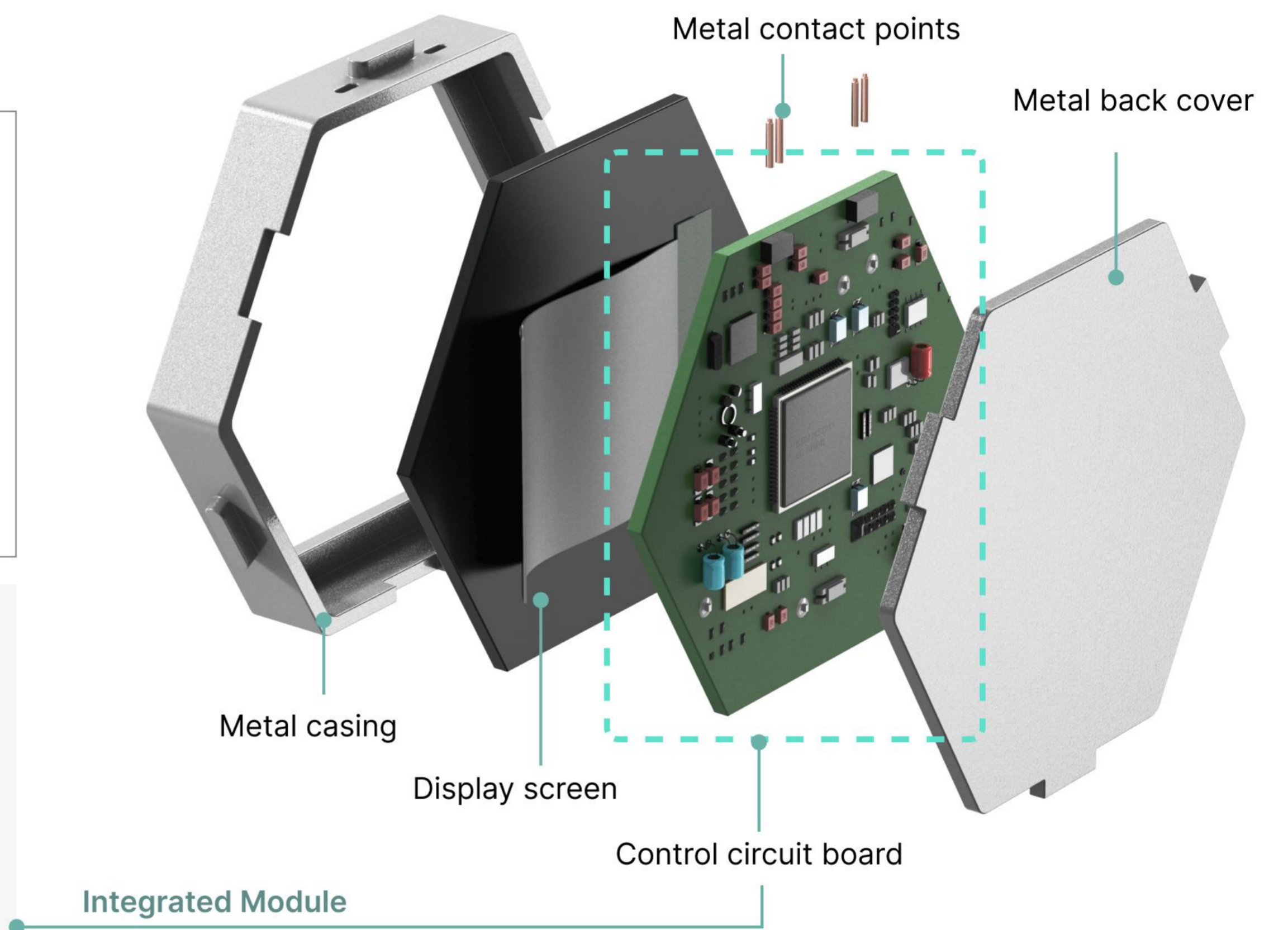

# Sensor Array

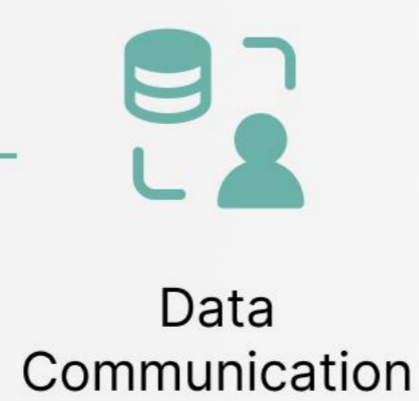
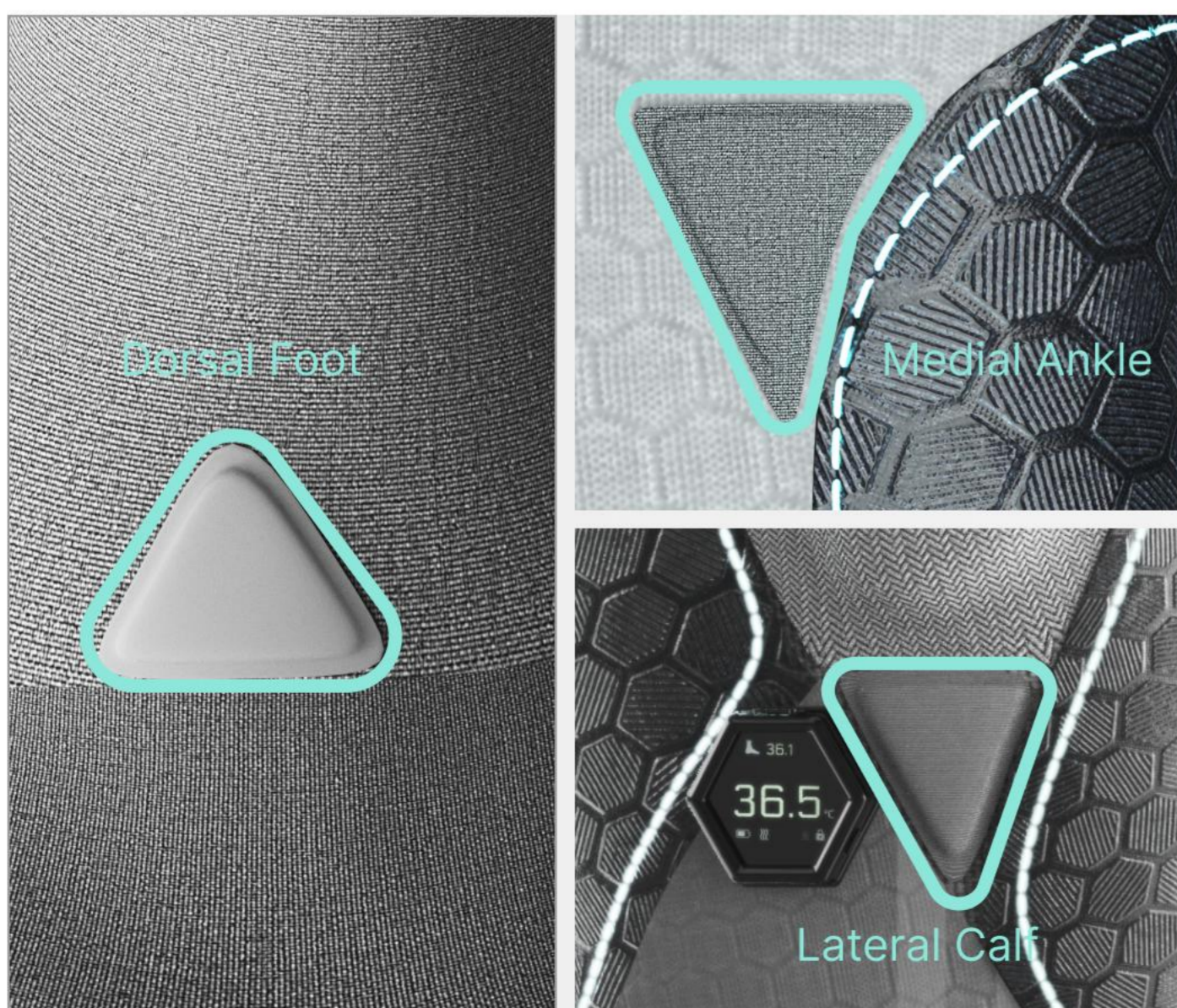

# Heating Drive Battery

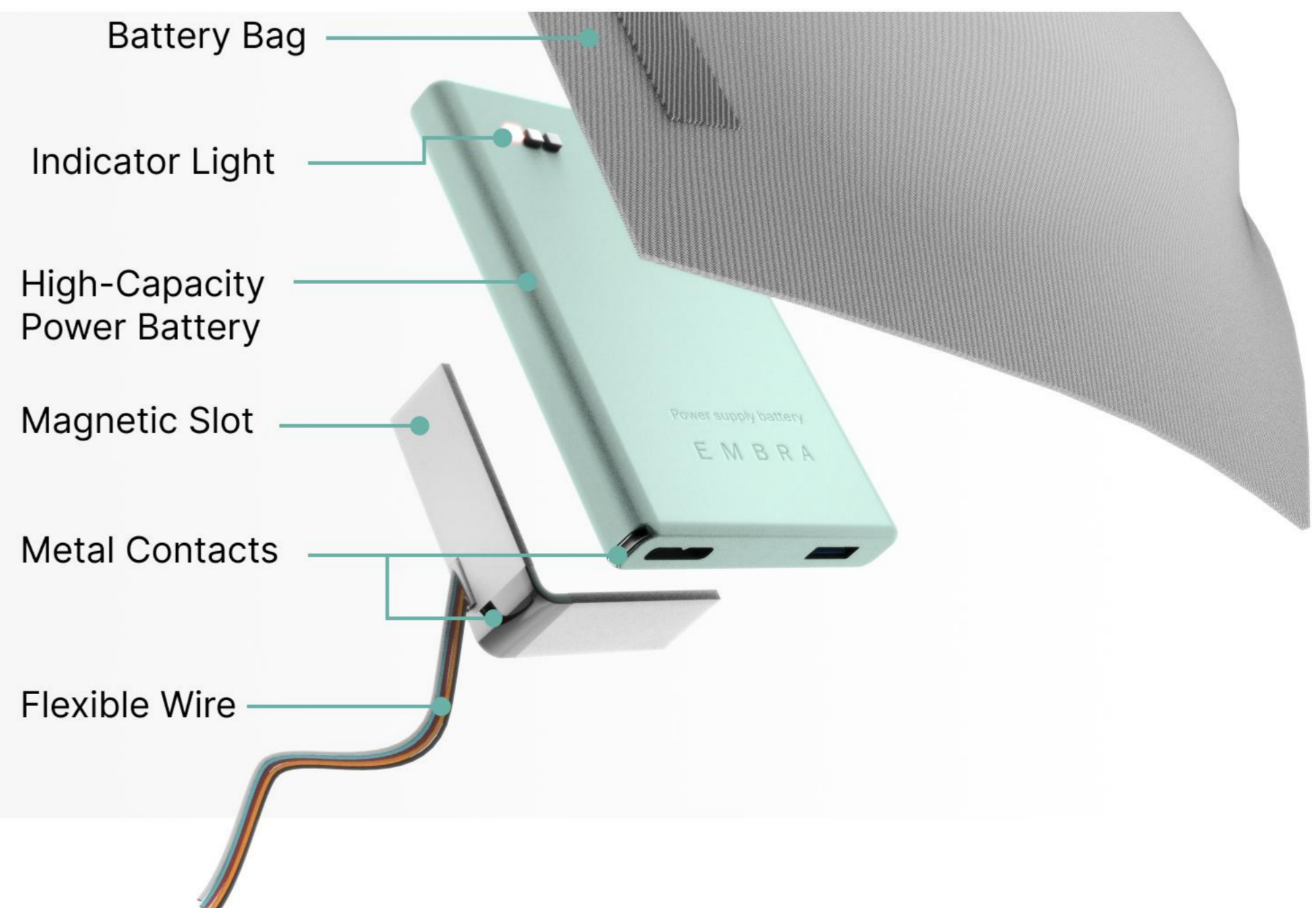

# UI Design

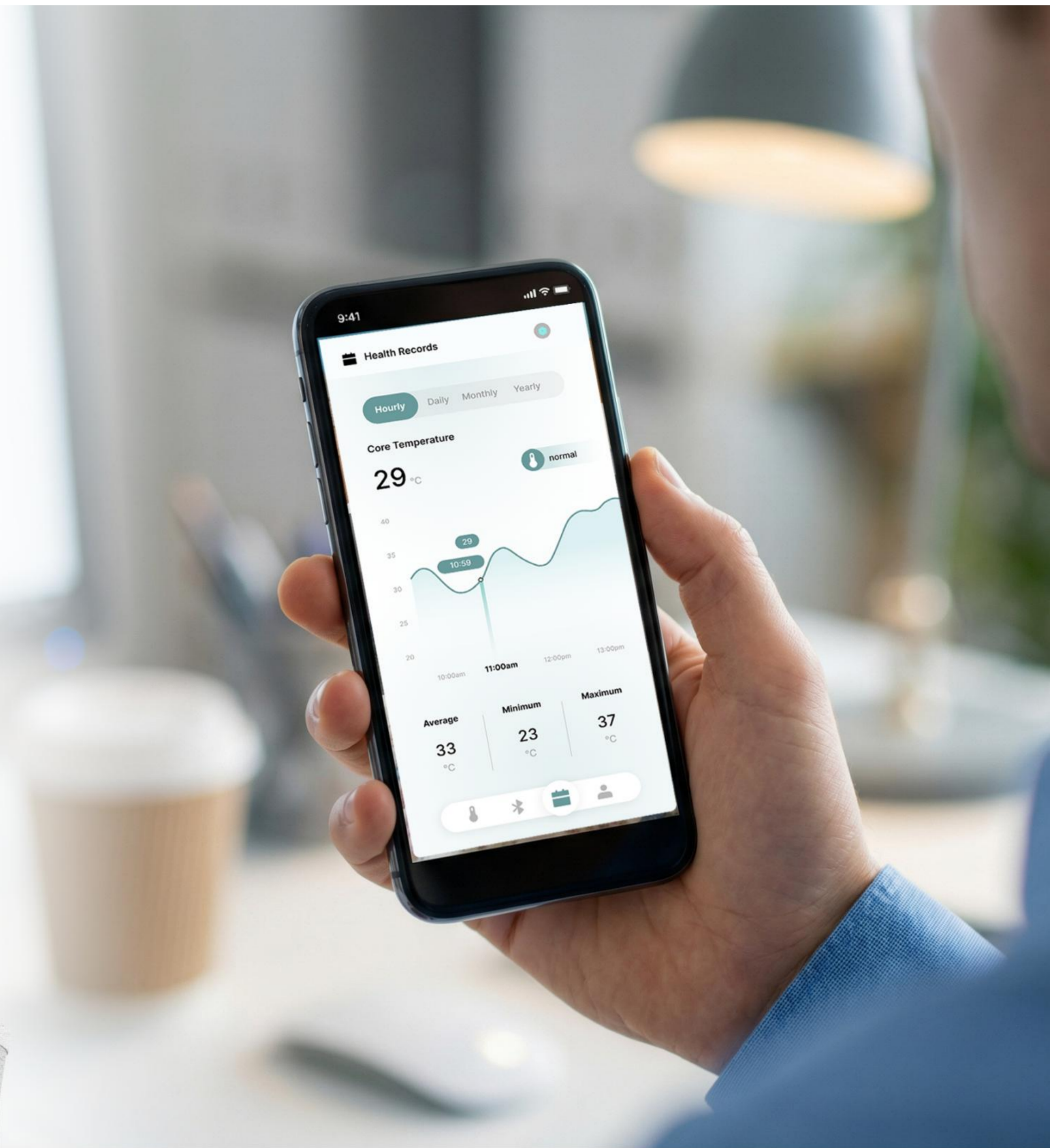
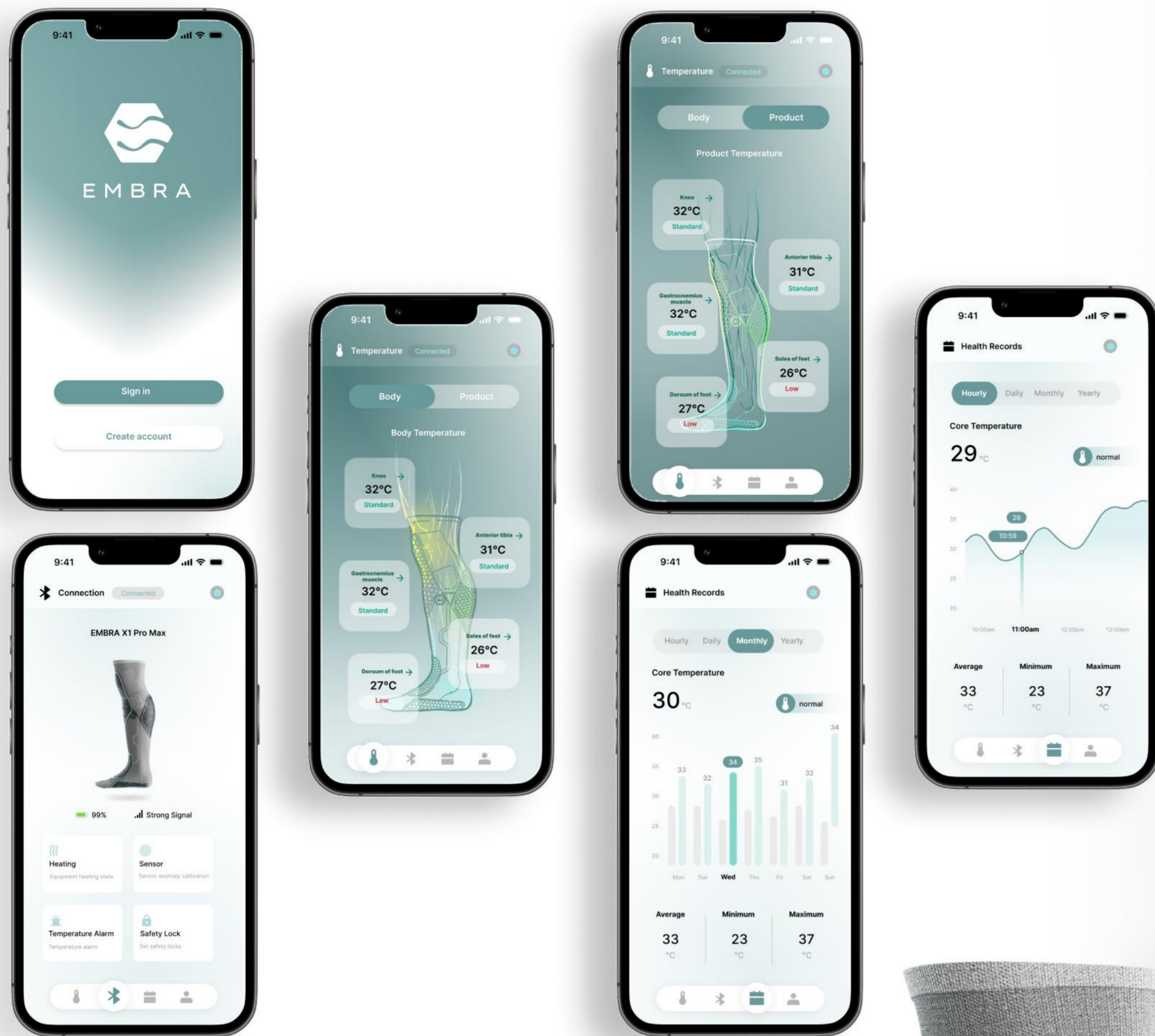

EMBRA syncs body and device temperature data to the app, allowing family members to monitor in real time. It also tracks long-term temperature history for better health assessment.

Compact screen shows temperature and heating status. Locked by default; hold 5 seconds to unlock. Alerts for abnormal temperature, with auto or manual adjustment.

EMBRA works both indoors and outdoors, safeguarding your health during exercise or while sleeping.



# CMF



The overall design employs a soft, low-saturation blue-green as its primary color palette, creating an atmosphere of care and comfort. The use of elastic materials ensures easy wearing and removal. Users can purchase the main control unit, battery, long socks, or short socks separately, enabling modular resource utilization. The package includes a clear and concise user manual, designed for easy understanding by elderly users.

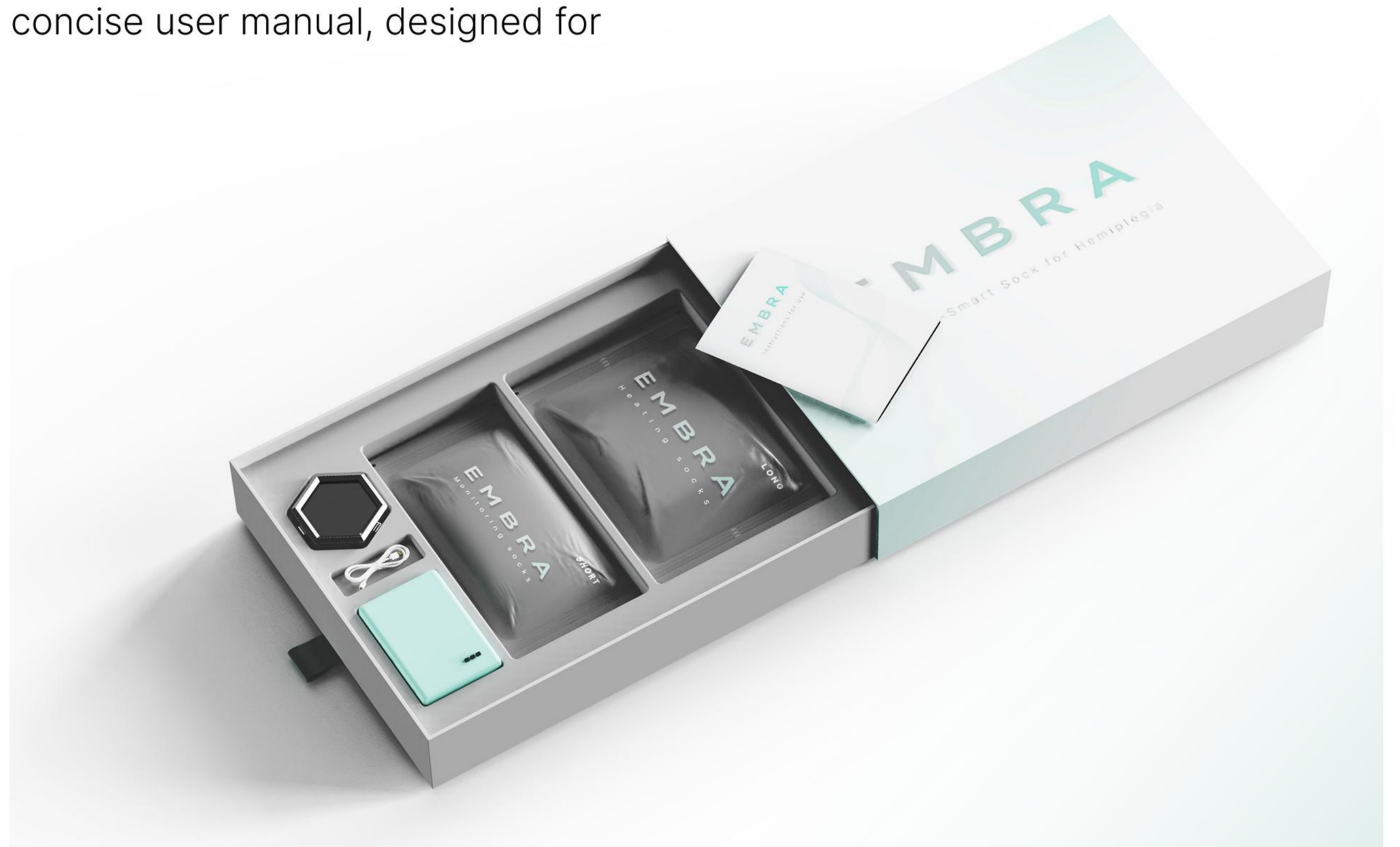
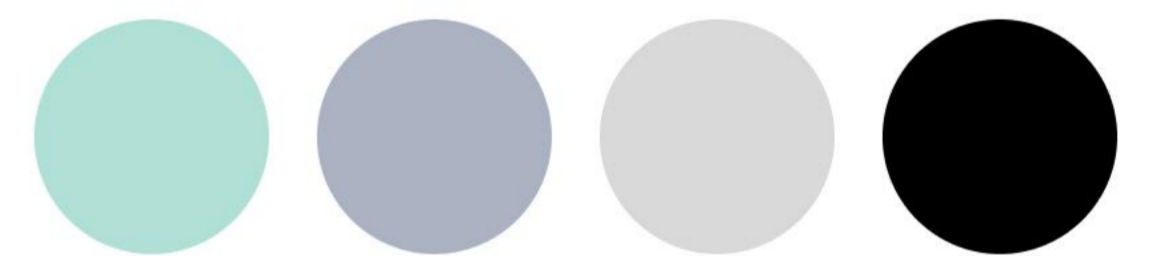

## Design Challenge

Currently, the EMBRA system requires further optimization for extreme temperatures, and its personalized precision needs more clinical data. We plan to collaborate with rehabilitation institutions on clinical studies to refine temperature strategies.